

KickingHorse®

WELDING INVERTER FOR HOME

OPERATION MANUAL

A220 Arc Welding Machine



LISTED

Serial Number: _____

Where Purchase: _____

Date of purchased: _____

KickingHorse

CONTENT

| | |
|---|---|
| 1. Safety | 2 |
| 2. Summary | 4 |
| 3. Electrical principle drawing | 5 |
| 4. Specifications | 6 |
| 5. Operation control and connectors | 6 |
| 6. Installation & Operation..... | 7 |
| 6.1 Installation | 7 |
| 6.2 Welding parameters | 7 |
| 7. Safety precaution | 8 |
| 7.1 Installation | 8 |
| 7.2 Safety | 8 |
| 8. Maintenance..... | 8 |
| 9. Troubleshooting & Service | 9 |

1. Safety



- ❖ Welding may damage your body or others, so please take protection measure in operation
- ❖ Only ones who are trained professionally can install , debug, operate, maintain and repair the equipment.

- ❖ Do not maintain and repair the machine when the machine is connected with power.



Electric shock can kill

- ❖ Never touch electrical parts.
- ❖ Wear dry, hole-free gloves and clothes to insulate yourself.
- ❖ Insulate yourself from work and ground using dry insulation. Make certain the insulation is large enough to cover your full area of physical contact with work and ground.
- ❖ Ensure to install the equipment correctly and ground the work or metal to be welded to a good electrical (earth) ground according the operation manual.
- ❖ Ensure to operate the equipment in safe position.



Fumes and gasses can be dangerous

- ❖ Welding may produce fumes and gases hazardous to health. Avoid breathing these fumes and gases. When welding, keep your head out the fume.
- ❖ Using enough ventilation and/or exhaust at the arc to keep fumes and gases away from the breathing zone.



Welding sparks can cause fire or explosion

- ❖ Remove fire hazards from the welding area. If this is not possible, cover them to prevent the welding sparks from starting a fire. Remember that welding sparks and not materials from welding can easily go through small cracks and openings to adjacent areas.



Do not weld enclosed tanks or containers

- ❖ Prohibit to use welder to unfrozen.
- ❖ Have a fire extinguisher readily available.



Hot parts can lead to burn

KickingHorse

- ❖ Do not touch the hot parts.
- ❖ Please use the torch after cooling or use the welding blow lamp.
- ❖ The people with heart-pacemaker should be away from the welding arc.



Rotating parts may be dangerous

- ❖ Far away from rotating parts. (like fan)
- ❖ Keep the parts of machine in the safe position.

2. Summary

A220 is a MMA arc welder which adopts the insulated gate bipolar transistor(IGBT) power module.

It can change work frequency to medium frequency so as to replace the traditional hulking work frequency transformer with the cabinet medium frequency transformer.

Thus, it is characterized with portable, small size, light weight, low consumption and noise etc.

A220 has excellent performance: constant current output makes welding arc more stable; fast dynamic response speed reduces the impact from the arc length fluctuation to the current.

There are also some automatic protection functions for under voltage, over current, over heat, etc. inside the welders, when the problems listed before occurred, the alarm on the front panel is light and at the same time the output current will be cut off. It can self-protect and prolong the using life and greatly improved the reliability of the welders.

A220 can be ignited easily, also with little splash and good weld bead.

A220is widely used in Petroleum, chemical, mechanical, shipbuilding, architecture, boiler, pressure container, war industry and installation and so on. This machine has high duty cycle even in the 40°C, which can keep the continuous operation. The frame is Stability of the machine, which can keep working under high temperature and corrosion environment.

3. Electrical principle drawing

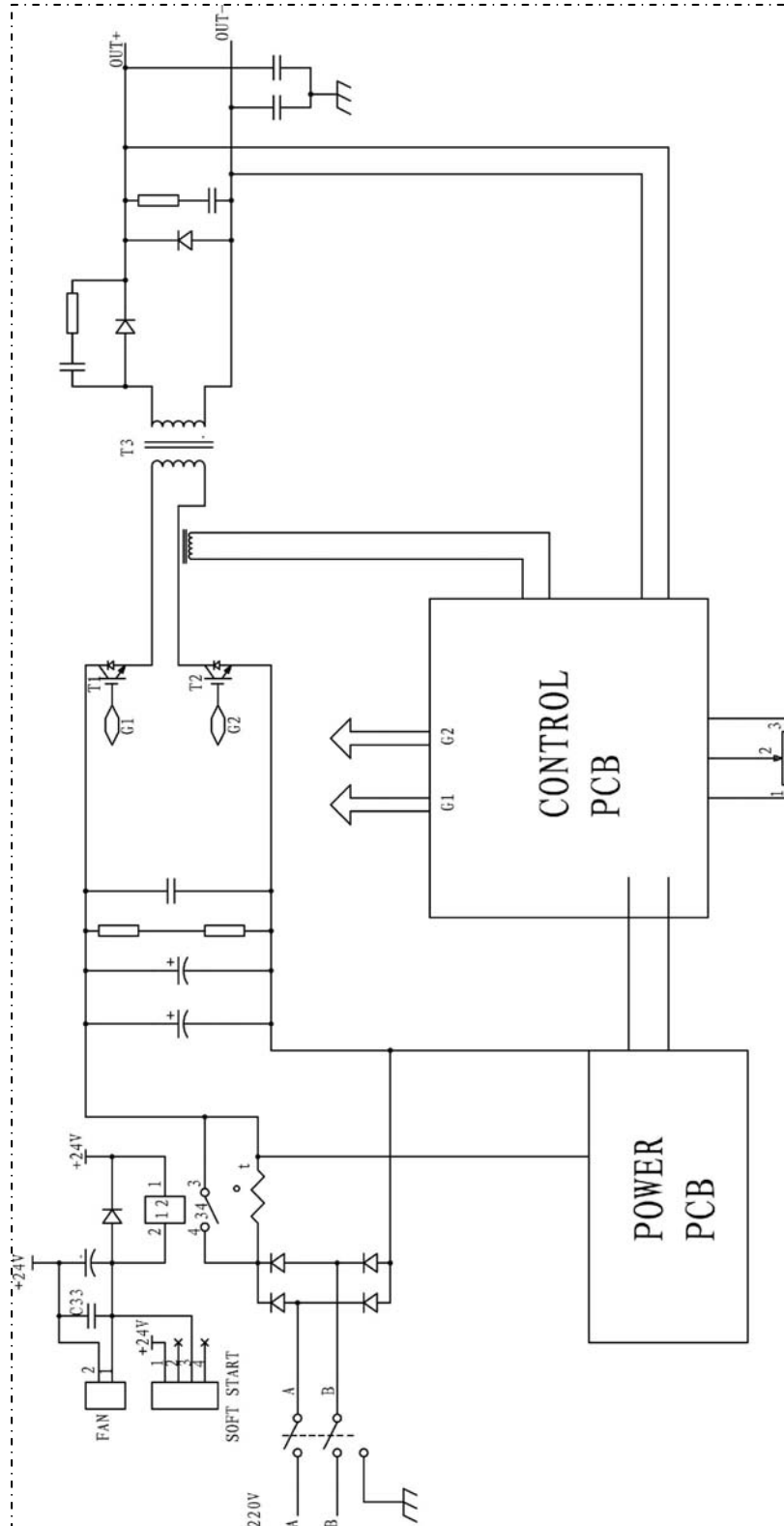

4. Specifications

| Parameters \ Models | A220 |
|--------------------------|---------------------------|
| Power Supply Voltage (V) | 208/230±10%, single phase |
| Frequency(HZ) | 60 |
| Rated input power (KW) | 7.2 |
| Duty cycle (40°C 10 min) | 25% 220A |
| | 60%145A |
| | 100%125A |
| No Load Voltage(V) | 74 |
| Efficiency (%) | ≥80% |
| Power Factor | 0.65 |
| Insulation class | H |
| Protection class | IP23 |
| Cooling | AF |
| Net Weight(Kg) | 3.5 |
| Dimensions(mm) | 230x120x170 |
| Electrode Diameter | 16/1~3/16 |
| Electrode Type | 6013,7018 etc. |

5. Operation control and connectors

Front Panel (Figure A below)

- (1) Positive output: Connect electrode holder.
- (2) Negative output: Connect to earth clamp.
- (3) Welding current adjustment knob: Turn this knob to adjust the output current.
- (4) Power indicator: power indicator, power on light on.
- (5) Alarm light: alarm indicator, lights that occurred over voltage, over current, or overheating inside the machine, is protected.

Rear panel (as shown in Figure B)

- (6) Power cord.
- (7) Power switch: control power.

(8) Fan.

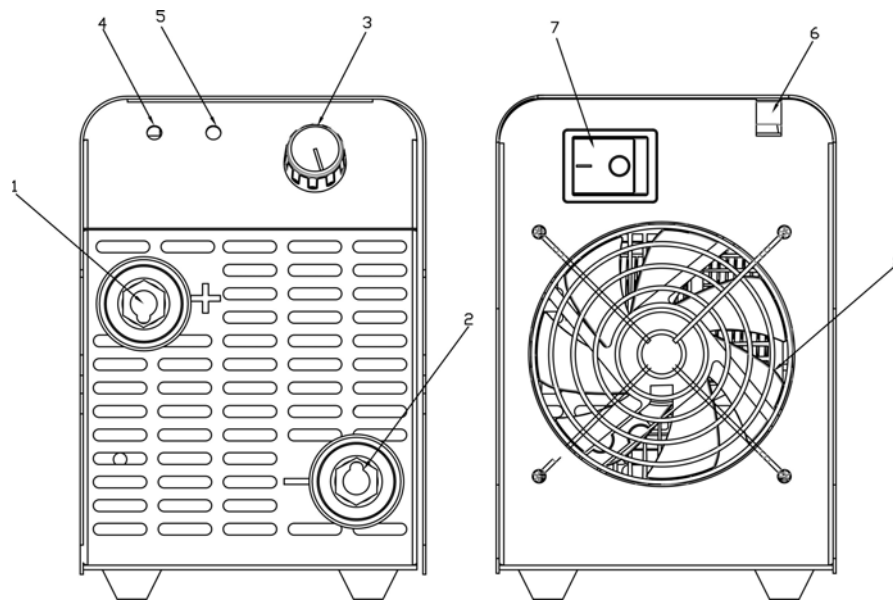

Figure A

Figure B

6. Installation & Operation

Electrical connection operation must be shut after power distribution box power switch!

The equipment protection level is IP23. Do not use in the rain!

6.1 Installation

(1) Welding machine should be installed in a stable position and with good ventilation. Avoid direct sun outdoors or rain. Place at a distance of 12" (300mm) or more from walls or similar that could restrict natural air flow for cooling. Avoid transport in invert or side position.

(2) Switch the ON/OFF Switch (located on the rear panel) to OFF.

(3) Connect electrode holder to positive connection and earth cable to negative connection. Insert Electrode holder/earth clamp quick connector into receptacle and turn 90° clockwise.

(4) Connect the earth clamp to your work piece.

6.2 Welding parameters

Note: The following table applies to low-carbon steel, other materials, please refer to related information.

| Electrode diameter (mm) | Recommended welding current(A) |
|-------------------------|--------------------------------|
| 1.0 | 20~60 |
| 1.6 | 44~84 |
| 2.0 | 60~100 |
| 2.5 | 80~120 |
| 3.2 | 108~148 |

KickingHorse

| | |
|-----|-------------------|
| 4.0 | 140~180 |
| 5.0 | 180~260 27.2~30.4 |

7. Safety precaution

7.1 Installation

- (1) Welding environmental temperature should be between -10°C to 40°C.
- (2) The air humidity of not more than 90%.
- (3) Avoid environment containing dust or corrosive gas.
- (4) Avoid sunlight or rain, do not let water into the welding machine.
- (5) Avoid the strong wind environment.

7.2 Safety

Refer to the American National Standard Z49.1 entitled: SAFETY IN WELDING AND CUTTING. **ALL INSTALLATION, OPERATION, MAINTENANCE, AND REPAIR WORK MUST BE PERFORMED BY QUALIFIED PERSONAL.**

1. Welders must be equipped with welding mask, gloves and tie the sleeves and collar properly. Use Table 6.4 to choose proper glass shade, also can reference to ANSI Z49.1 listed in Safety Standards. There should be an arc shield around welding field to protect others from arc shock.
2. Do not weld near flammable, explosive materials or gases.
3. Keep finger, hair and clothing away from the rotating fan.
4. The power source must be grounded when welding.
5. When yellow protection light is enlightened during welding, it is indicating that the welder is over current or over heat, and automatic protection will be triggered. Stop welding immediately and wait until welder cool down.
6. Welding machine should not work in a flammable and toxic environment, avoid moisture, rain, and do not directly expose to sun.
7. Do not switch off the welder during welding!
8. Periodically maintain the machine and clean the dust inside.

8. Maintenance

Periodic maintenance is necessary for keeping the machine work properly.

DISCONNECT POWER INPUT AND SWITCH OFF THE MAIN POWER SWITCH BEFORE START OF MAINTENANCE.

| Regular Check and Inspection | 6 Month Routine Maintenance |
|---|---|
| <ul style="list-style-type: none"> • Replace unreadable labels. • TIG-Clean spatter inside the nozzle when continuously use the machine • TIG-Check and change broken parts in the torch to avoid damage to the torch and machine. • Check the function of all switches. • Check if the fan rotates properly and if there is air | <ul style="list-style-type: none"> • Blow out with dry clean pressure air or vacuum inside machine, especially transformer coil and power component. • Check the electric connection of input/output bar to avoid bad contact caused by loose or rusted screw. • Check the contactors and relays in the machine or on the PCB work properly. |

KickingHorse

| | |
|---|---|
| <p>venting out from back of the machine.</p> <ul style="list-style-type: none"> • Pay Attention to the abnormal vibration, noise, smell and gas leakage during operation. • Check if the welding cables are over heated. • Check if the cable connections are over heated. • Check if the cable is connected firmly and properly, if it is broken and cause bad insulation. • Check the cover grounded properly. | <ul style="list-style-type: none"> • Calibrate the current meter. • Check the resistance between machine case and main circuit, if the value is smaller than $1M\Omega$, sent the machine to an authorized warranty depot to inspect and repair immediately. |
|---|---|

9. Troubleshooting & Service

The following operations require the operator has sufficient electrical expertise and comprehensive safety knowledge, the operator can demonstrate its capacity to be held valid qualifications and knowledge Documents.

Common Faults and exclusion method:

| Symptom | Solution |
|---|--|
| Power indicator does not light, fan does not turn, no welding output. | <ol style="list-style-type: none"> 1. Make sure the power switch is turned on. 2. Confirm that the power input cable is connected with electricity. |
| Symptom | Solution |
| Fan switch, or not subject to potential instability in the welding current control, current, big, sometimes small | <ol style="list-style-type: none"> 1. The current potential is damaged, should be replaced. 2. Bad connections, such as plug-in to be checked. |
| Power indicator light shows the normal fan rotating normal, no welding output. | <ol style="list-style-type: none"> 1. Check all connectors inside the machine if there is bad. 2. a circuit output connections or bad. 3. the alarm indicator light <ul style="list-style-type: none"> (1)that access to protected status because of overheating, in which case, To maintain power, so that the temperature dropped to the machine fan Reasonable temperature, until light goes out, you can continue working; (2)Check the thermal switch is damaged, such damage, to be Replacement. |
| Hot welding clamp | Welding clamp rated current is too small, the replacement of larger size welding clamp. |
| Manual welding big splash | Output polarity is unreasonable, reversed output connector |

NOTES

A220 power source

KickingHorse

KICKINGHORSE® WELDER CANADA
12-3400 Ridgeway Drive, Mississauga, Ontario, L5L 0A2, Canada
Tel: 1 866 686 5088
Fax: 1 866 686 5090
Website: www.kickinghorsewelders.ca
Printed March 26, 2017